

GE Digital Energy Power Quality

Introduction

Voltage spikes and surges from both external and internal sources can cause damage to all electronics and directly affect the performance and life expectancy of connected equipment. From electronic lighting ballasts to computer servers, if there is a printed circuit board inside, it is susceptible to transient voltage surge damage. As microprocessors and components that make up this equipment grow smaller and faster with each new generation, their susceptibility to transient voltage surge damage becomes ever greater.

The TR5000 series is ideal for both new and retrofit commercial and industrial applications where basic monitoring is required and performance cannot be compromised. Available in ratings from 25kA - 100kA per mode, (50kA - 200kA per phase) the TR5000 series is the perfect surge suppression product for protecting your critical sensitive electronic equipment throughout your facility.

Recommended installation locations are primary and secondary distribution and point of use levels. Designed for distribution and point of use locations but rated for service entrance, the TR5000 series has been third-party tested to ANSI/IEEE C3 (10kA 8 x 20µs) impulses. The entire TR5000 line-up has been engineered to the highest standards and is designed for rigorous duty and long life as evidenced in our outstanding minimum repetitive surge current capacity test results.

Features and Benefits

- > The TR5000 provides maximum surge protection with outstanding clamping characteristics for medium and low exposure locations through the use of industrial grade MOV architecture.
- > UL 1449 3rd Edition, Type 2
- > Third-party tested per IEEE C62.62 and NEMA LS-1 for the rated 8x20µs surge current, per mode with fusing included.
- > Maximum installation flexibility is achieved in the TR5000 through its high surge suppression ratings to small footprint size ratio.
- > Fast rise-times, high frequency transients and electrical line noise are reduced with standard EMI / RFI filtering technology on 65, 80 and 100kA per mode products (Not applicable for 25 and 50kA)
- > 10 modes of protection (L-N, L-G, N-G, L-L)
- > Green phase protection status LEDs
- > NO/NC Form C Dry Contacts for remote monitoring
- > Patented thermal fuse technology
- > Standard heavy gauge painted steel NEMA 12 construction, available in surface or flushmount
- > Durable fiberglass construction for NEMA 4X
- > 5 year limited warranty (standard), 10 year limited warranty (optional)

Wallmount

TR5000 Series

Surge Protective Device (SPD)



Standards

- > UL 1449 3rd Edition, Type 2
- > UL 1283, EMI/RFI noise filter (only 65, 80, 100kA)
- > UL 96A, Lightning Protection System
(only 65kA - 100kA models can be used in UL 96A Lightning Protection Systems)
- > ANSI/IEEE C62.41 - ANSI/IEEE C62.45
- > IEEE C62.62
- > cUL, CSA C22.2
- > NEMA LS-1 - 1992 (R2000)
- > MIL-STD-220B
- > ANSI/NFPA 70 (Article 285)

Minimum Repetitive Surge Current Capacity

(Per ANSI/IEEE C62.62)

The TR5000 Series is capable of surviving the following impulses, at one-minute intervals, without failure and with less than 10% change in protective characteristics.

- > **5,000** Category C3 impulses 20kV/10kA, 8x20µs for 65-100kA rated devices
- > **3,500** Category C3 impulses 20kV/10kA, 8x20µs for 25-50kA rated devices
- > **5,000** 500V/2kA, 10x1000µs long wave impulses for 65-100kA rated devices

Applications

- > Distribution Equipment
- > Branch Panel
- > Point of Use
- > New Construction and Retrofits
- > System Expansions

Technical Specifications

Nominal Discharge Current (I_n)

25kA - 50kA rated units: 10kA

65kA - 100kA rated units: 20kA

Short Circuit Current Rating (SCCR)

65kA (30A breaker required)

Operating Frequency

50/60 Hz

Connection

10 AWG Pre-wired Conductors, Parallel Connected

Operating Temperature

-40° F to 149° F (-40° C to +65° C)

Operating Humidity

NEMA 12 0% to 95%

NEMA 4X Non-Condensing 0% to 100%

Weight

25-50kA 11.7 lbs. (5.31 kg)

65-100kA 19.7 lbs. (8.94 kg)

NEMA 12 Surfacemount Dimensions – WM Suffix

25, 50kA per mode

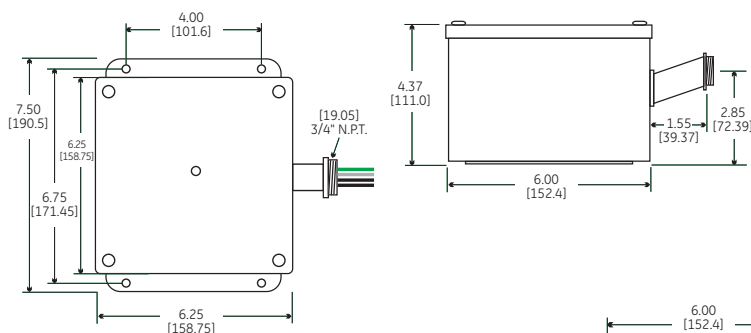

65, 80, 100kA per mode

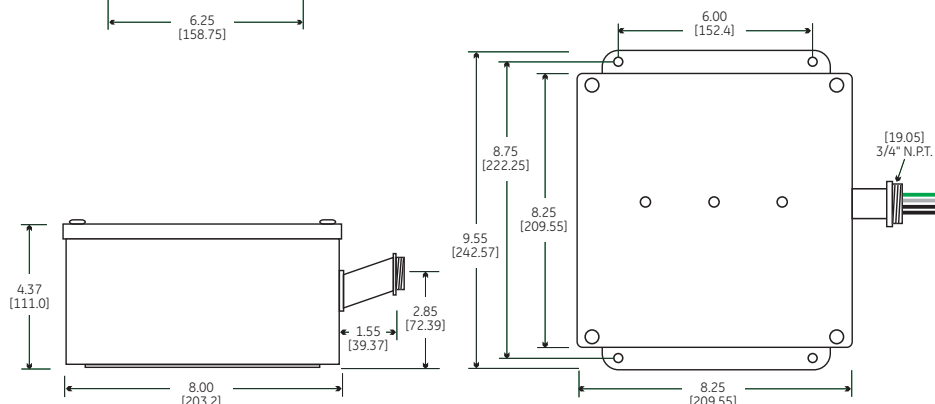

NOTE:

All dimensions are for reference only and are shown in Inches (millimeters)

Catalog # TR 5

WM

	Nominal Voltage (Volts RMS)	System Voltage Configuration	MCOV % Max. Continuous Operating Voltage	Source Configuration	Maximum Surge Current Capacity		Suffix*	Enclosure Description	NEMA	Mounting
					Per Mode	Per Phase				
120S	120/240	1 Ph, 3 W + G	150V	A	025	25kA 50kA		Painted Steel	12	Surface
120Y	120Y/208	3 Ph, 4 W + G	150V	B	050	50kA 100kA	F	Painted Steel	12	Flush
220Y	220/380	3 Ph, 4 W + G	320V	B	065	65kA 130kA	4	Fiberglass	4X	Surface
240Y	240/415	3 Ph, 4 W + G	320V	B	080	80kA 160kA				
277Y	277Y/480	3 Ph, 4 W + G	320V	B	100	100kA 200kA				
240D	240 Delta	3 Ph, 3 W	270V	C	Phase Rating = (L-N + L-G)					
480D	480 Delta	3 Ph, 3 W	550V	D						
240H	120/240 Delta HL	3 Ph, 4 W + G	see Note	E						

Note: 150V (L-N/G) Phase A&C; 270V (L-N-G) Phase B

Catalog # example: TR5277Y100WM

- 277Y/480 V, 3 Ph, 4W + G
- 100kA per mode
- NEMA 12, surface mount

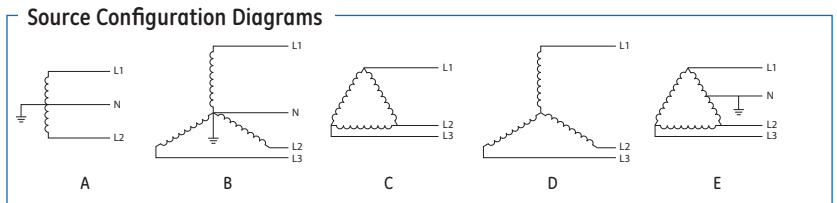

025, 050kA Protection Ratings

Voltage Code	120S / 120Y				240D		240H						220Y / 240Y / 277Y				480D		
	L-N	L-G	N-G	L-L	L-G	L-L	L-N	HL-N	L-G	HL-G	N-G	L-L	HL-L	L-N	L-G	N-G	L-L	L-G	L-L
UL 1449, 3 rd Edition Voltage Protection Ratings (VPR) (assigned UL rating)	600	600	600	1000	900	1800	600	1200	600	1000	600	1000	1800	1200	1000	1200	1800	1800	4000
UL 1449, 2 nd Edition Suppression Voltage Ratings (SVR) (assigned UL rating) *	500	500	500	—	800	—	500	800	500	800	500	—	—	800	800	800	—	1500	—

065, 080 & 100kA Protection Ratings

Voltage Code	120S / 120Y				240D		240H						220Y / 240Y / 277Y				480D		
	L-N	L-G	N-G	L-L	L-G	L-L	L-N	HL-N	L-G	HL-G	N-G	L-L	HL-L	L-N	L-G	N-G	L-L	L-G	L-L
UL 1449, 3 rd Edition Voltage Protection Ratings (VPR) (assigned UL rating)	900	1000	900	1500	1500	2000	900	1500	1000	1500	900	1500	2500	1500	1500	1500	2500	1800	4000
UL 1449, 2 nd Edition Suppression Voltage Ratings (SVR) (assigned UL rating) *	400	400	400	—	700	—	400	700	400	700	400	—	—	900	800	1500	—	1500	—

* NOTE: SVR Ratings are no longer assigned by UL and are included in the table above for reference purposes only.

NEMA 12 Flushmount Dimensions – WMF Suffix

25, 50kA
per mode

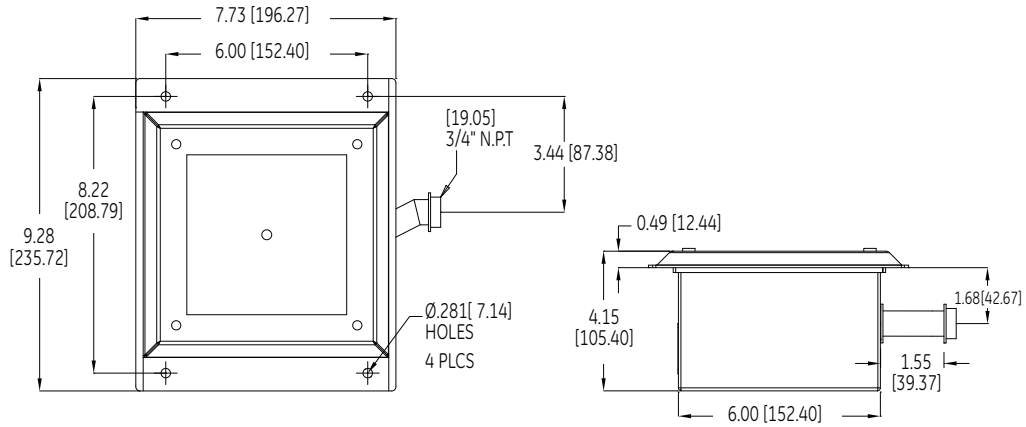

65, 80, 100kA
per mode

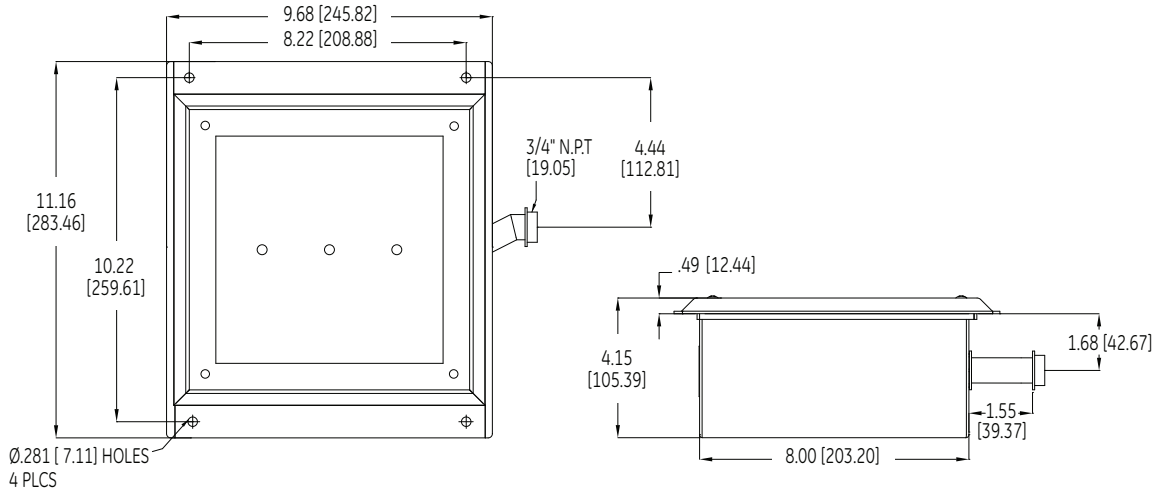

NEMA 4X Dimensions – WM4 Suffix

25, 50kA per mode

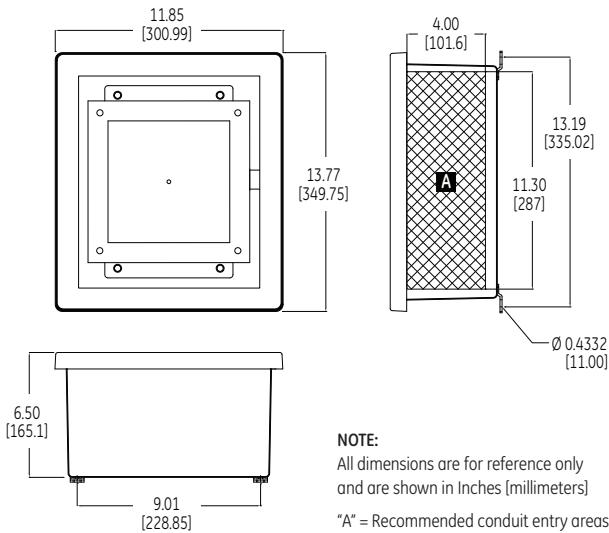

65, 80, 100kA per mode

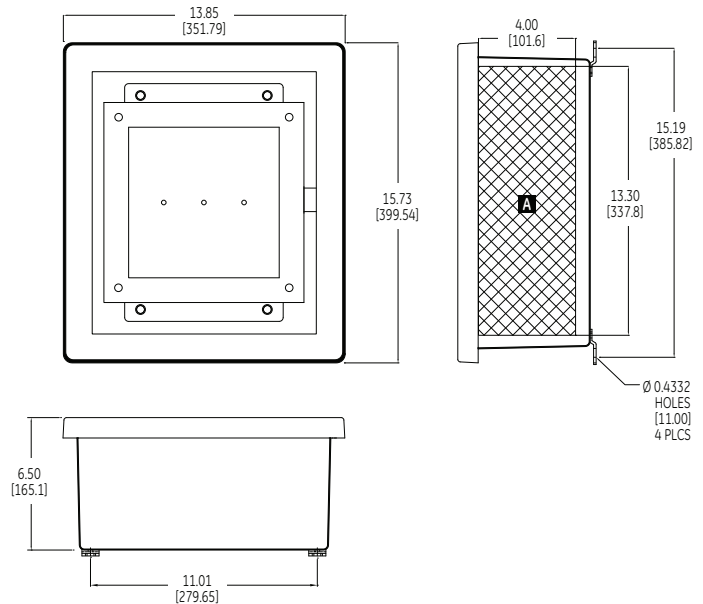

NOTE:
All dimensions are for reference only
and are shown in Inches (millimeters)
"A" = Recommended conduit entry areas
Refer to instruction manual for details



GE Digital Energy – Power Quality
830 W 40th Street, Chicago, IL 60609 USA
800 637 1738 www.gepowerquality.com

Information subject to change without notice. Please verify all details with GE.
DEA-367 (12/09) © 2009 General Electric Company All Rights Reserved